

WIRING DIAGRAM

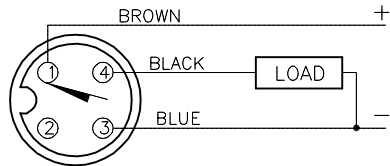

OUTPUT: AP6X
SHORT-CIRCUIT AND OVERLOAD PROTECTED

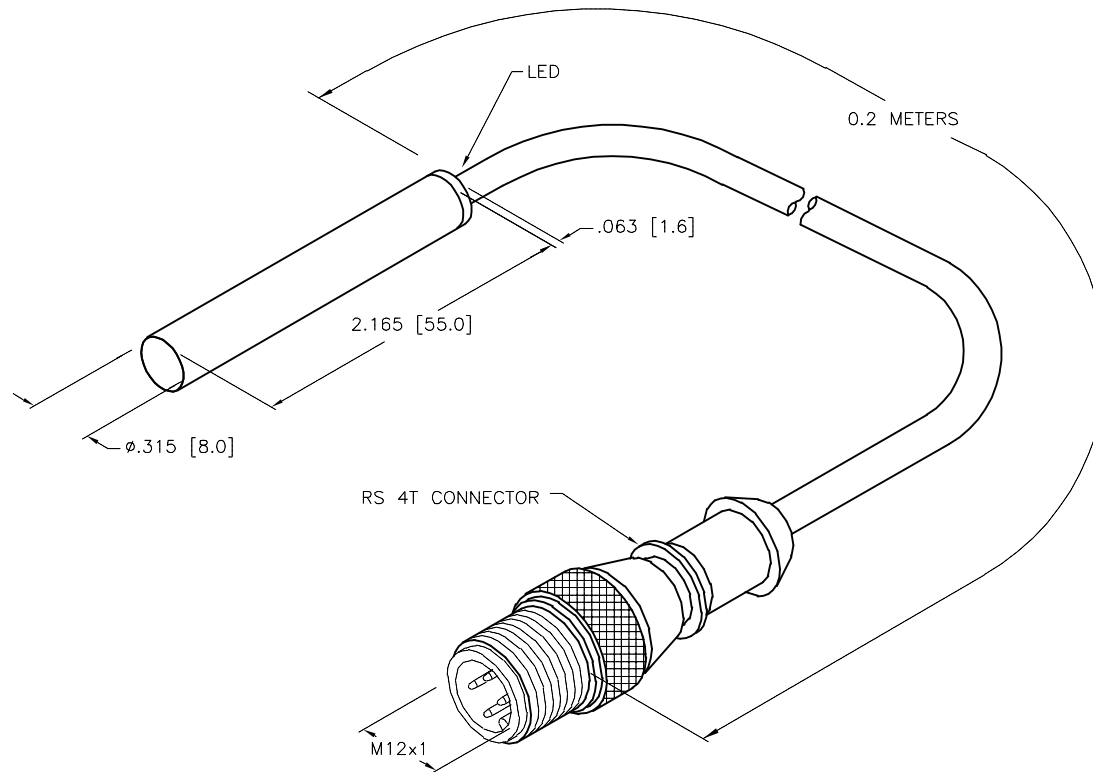

SPECIFICATIONS

RATED OPERATING DISTANCE	1.5 mm [0.059"]
HYSTERESIS	1-15%
MIN. REPEAT ACCURACY	≤ 5%
MAX. TEMPERATURE DRIFT	≤ ±10% C°
OPERATING TEMPERATURE	-25°C to +70°C (-13°F to +158°F)
RATED OPERATIONAL VOLTAGE	10-30 VDC
RESIDUAL RIPPLE	≤ 10%
RATED OPERATIONAL CURRENT (DC)	≤ 150 mA
NO LOAD CURRENT	≤ 15 mA
RESIDUAL CURRENT	≤ 10 μA
TRIGGER CURRENT FOR OVERLOAD PROTECTION	≥ 170 mA
TIME DELAY BEFORE AVAILABILITY	≤ 8 ms
MAX. SWITCHING FREQUENCY	≤ 2 kHz
OUTPUT FUNCTION	3-WIRE, NORMALLY OPEN, PNP
SHORT-CIRCUIT PROTECTED	YES
MAX. VOLTAGE DROP	≤ 1.8 V @ 150 mA
WIRE-BREAK PROTECTION	INCORPORATED
REVERSE POLARITY PROTECTION	INCORPORATED
CABLE	TPU, 4mm OD
VIBRATION RESISTANCE	55 Hz, 1 mm AMPLITUDE (IN ALL 3 PLANES)
SHOCK RESISTANCE	30 g, 11 ms
DEGREE OF PROTECTION	IP 67
SWITCHING STATUS INDICATION	LED, YELLOW

SOURCE DRAWING - FOR REFERENCE ONLY

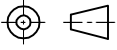
RELATED DOCUMENTS		3RD ANGLE PROJECTION		THIS DRAWING IS CONFIDENTIAL AND THE PROPERTY OF TURCK INC. USE OF THIS DOCUMENT WITHOUT WRITTEN PERMISSION IS PROHIBITED.		 3000 CAMPUS DRIVE MINNEAPOLIS, MN 55441 1-800-544-7769 (763) 553-7300 (763) 553-0708 fax www.turck.us	
1. 2. 3. 4.				DRFT NF	DATE 02/03/20	DESCRIPTION B11.5-H08-AP6X-0.2-PSG3M	
MATERIAL BRASS BARREL		ALL DIMENSIONS DISPLAYED ON THIS DRAWING ARE FOR REFERENCE ONLY		APVD A.F.	SCALE 1=1.0	IDENTIFICATION NO. 1604392	
FINISH COPPER/NICKEL/ CHROME PLATING		CONTACT TURCK FOR MORE INFORMATION		UNIT OF MEASUREMENT INCH [MILLIMETER]		REV A	
A DRAWING RELEASE		NF	02/03/20	DO NOT SCALE THIS DRAWING		FILE: 1604392	
REV	DESCRIPTION	BY	DATE	ECO NO.	SHEET 1 OF 1		